

29.4

SZCZEGÓŁ B

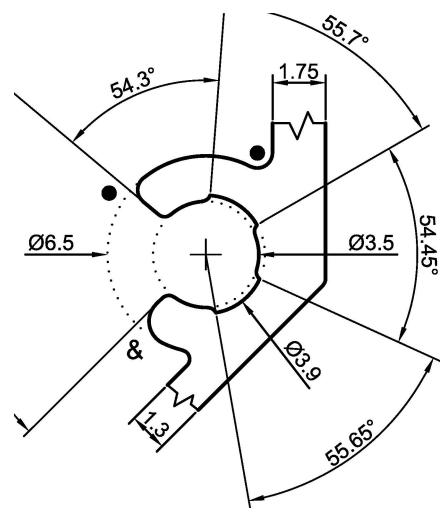

1.75

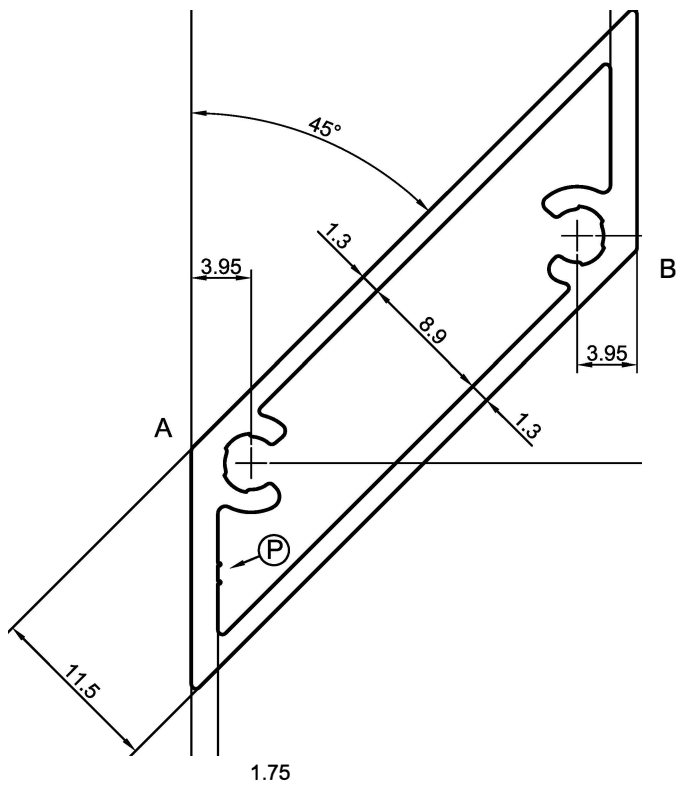

5

SZCZEGÓŁ A

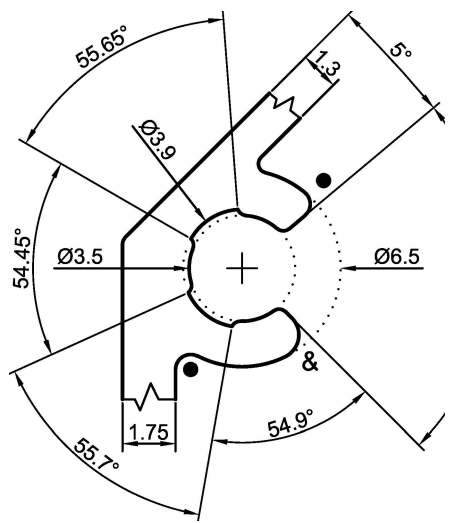

$\&=R0.8\text{ mm}$